



7 Frame Plunger Pump

**Standard
Models**

53, 55

**Gearbox
Models**

51, 58

FEATURES

Superior Design

- Triplex plunger design gives smoother liquid flow.
- Hi-Pressure Seals or V-Packings are completely lubricated and cooled by the liquid being pumped.
- Inlet and discharge valve assemblies interchange for easier maintenance.
- Lubricated Lo-Pressure Seals provide double protection against external leakage.
- Oil bath crankcase assures optimum lubrication.
- Close tolerance concentricity of the ceramic plunger maximizes seal life.
- Optional Gearbox Pump version for direct mounting to gas engine.

Quality Materials

- Precision design 304 stainless steel valves and seats are hardened and polished for ultimate seating and extended seal life.
- Forged brass manifold for strength and corrosion resistance.
- Special concentric, high-density, polished, solid ceramic plungers provide a true wear surface and extended seal life.
- Specially formulated, CAT PUMP exclusive, Hi-Pressure Seals or V-Packings offer unmatched performance and seal life.
- Die cast aluminum crankcase provides high strength, minimum weight and precision tolerance control.
- Chrome-moly crankshaft gives unmatched strength and surface hardness.
- Oversized crankshaft bearings with greater loading capacity mean longer bearing life.

Easy Maintenance

- Wet-end is easily serviced without entering crankcase, requiring less time and effort.
- Valve assemblies are accessible without disturbing piping, for quick service.
- Preset packings mean no packing gland adjustment is necessary, reducing maintenance costs.

⚠ WARNING

All systems require both a primary pressure regulating device (i.e., regulator, unloader) and a secondary pressure safety relief device (i.e., pop-off valve, safety valve). Failure to install such relief devices could result in personal injury or damage to the pump or to system components. CAT PUMPS does not assume any liability or responsibility for the operation of a customer's high pressure system.

SPECIFICATIONS

	U.S. Measure	Metric Measure	U.S. Measure	Metric Measure
Standard Models	53		55	
Flow	5.0 GPM	(19 L/M)	5.0 GPM	(19 L/M)
Pressure Range	100 to 2500 PSI	(7 to 175 BAR)	100 to 3000 PSI	(7 to 210 BAR)
Inlet Pressure Range	-5 to 60 PSI	(0.35 to 4 BAR)	-5 to 60 PSI	(0.35 to 4 BAR)
RPM	1100 RPM	(1100 RPM)	1415 RPM	(1415 RPM)
Bore.....	0.708"	(18 mm)	0.630"	(16 mm)
Stroke	0.945"	(24 mm)	0.945"	(24 mm)
Gearbox Models	51		58	
	Gearbox 51G1 or 51G118		Gearbox 58G1 or 58G118	
Flow	4.8 GPM	(18 L/M)	5.0 GPM	(19 L/M)
Pressure Range	100 to 3000 PSI	(7 to 210 BAR)	100 to 2500 PSI	(7 to 175 BAR)
Inlet Pressure Range	Fld to 60 PSI	(Fld to 4 BAR)	Fld to 60 PSI	(Fld to 4 BAR)
RPM	1765 RPM	(1765 RPM)	1570 RPM	(1570 RPM)
Bore.....	0.630"	(16 mm)	0.708"	(18 mm)
Stroke	0.728"	(18.5 mm)	0.669"	(17 mm)

COMMON SPECIFICATIONS

Crankcase Capacity25 oz.	(0.75 L)
Maximum Liquid Temperature160°F	(71°C)
For temperatures above 130°F call CAT PUMPS for inlet conditions and elastomer recommendations.		
Inlet Ports (2).....1/2" NPTF	(1/2" NPTF)
Discharge Ports (2)3/8" NPTF	(3/8" NPTF)
Shaft Diameter.....0.945"	(24 mm)
Weight26.5 lbs.	(12.0 kg)
Dimensions (Pump Only).....13.6 x 8.20 x 5.90" (345 x 208.30 x 150 mm)	

HORSEPOWER REQUIREMENTS

MODEL	FLOW		PRESSURE				MOTOR PULLEY SIZE	
	U.S. GPM	L/M	PSI 1800	PSI 2000	PSI 2500	PSI 3000	RPM	Pulley O.D.
53	5.0	19.0	6.2	6.9	8.6	N/A	1100	6.3
	4.5	17.0	5.6	6.2	7.7	N/A	990	5.6
	4.0	15.0	5.0	5.5	6.9	N/A	880	5.0
55	5.0	19.0	6.2	6.9	8.6	10.3	1415	8.0
	4.0	15.0	5.0	5.5	6.9	8.3	1130	6.4
	3.0	11.4	3.7	4.2	5.2	6.2	850	5.0
58	5.0	19.0	6.2	6.9	8.6	N/A	1570	Gearbox
51	4.8	18.0	5.9	6.6	8.2	9.8	1765	Gearbox

DETERMINING THE PUMP R.P.M.	<u>Rated G.P.M.</u>	=	<u>"Desired" G.P.M.</u>
	Rated R.P.M.	=	"Desired" R.P.M.
DETERMINING THE REQUIRED H.P.	<u>GPM x PSI</u>	=	Electric Brake
	1460	=	H. P. Required
DETERMINING MOTOR PULLEY SIZE	<u>Motor Pulley O.D.</u>	=	<u>Pump Pulley O.D.</u>
	Pump R.P.M.	=	Motor R.P.M.

See complete Drive Packages [Incls: Pulleys, Belts, Hubs, Key] Tech Bulletin 003.
Refer to pump **Service Manual** for repair procedure, additional technical information and **pump warranty**.

"Customer confidence is our greatest asset"

PARTS LIST

ITEM	PART NUMBER				DESCRIPTION	QTY
	51 MATL	55 MATL	53 MATL	58 MATL		
2	30067 STL	30067 STL	30067 STL	30067 STL	Key (M8x7.5x25)	1
5	92519 STZP	92519 STZP	92519 STZP	92519 STZP	Screw, Sems HHC (M6x16)	8
8	43466 AL	43466 AL	43466 AL	43466 AL	Cover, Bearing	1
9	815280 FBR	815280 FBR	815280 FBR	815280 FBR	Shim, Split, 2-Pc	1
10	12393 NBR	12393 NBR	12393 NBR	12393 NBR	O-Ring, Cover	2
11	43222 NBR	43222 NBR	43222 NBR	43222 NBR	Seal, Oil, Crankshaft - 70D	1
15	43221 STL	43221 STL	43221 STL	43221 STL	Bearing, Roller	2
20	48863 TNM	48863 TNM	48863 TNM	48863 TNM	Rod, Connecting Assy [6/02]	3
25	44947 FCM	43464 FCM	43464 FCM	44946 FCM	Crankshaft - Single End	1
30	44967 AL	44967 AL	44967 AL	44967 AL	Cover, Bearing, Blind	1
31	—	828710 —	828710 —	—	Protector, Oil Cap w/Foam Gasket	1
32	44666 RTP	43211 ABS	43211 ABS	44666 RTP	Cap, Oil Filler, Domed	1
33	14177 NBR	14177 NBR	14177 NBR	14177 NBR	O-Ring, Filler Cap - 70D	1
37	92241	92241	92241	92241	Gauge, Oil, Bubble w/Gasket - 80D	1
38	44428 NBR	44428 NBR	44428 NBR	44428 NBR	Gasket, Flat, Oil Gauge - 80D	1
40	92520 STZP	92520 STZP	92520 STZP	92520 STZP	Screw, Sems HHC (M6x20)	4
48	25625 STCP	25625 STCP	25625 STCP	25625 STCP	Plug, Drain (1/4"x19BSP)	1
49	23170 NBR	23170 NBR	23170 NBR	23170 NBR	O-Ring, Drain Plug - 70D	1
50	46509 AL	46509 AL	46509 AL	46509 AL	Cover, Rear	1
51	44836 NBR	44836 NBR	44836 NBR	44836 NBR	O-Ring, Rear Cover - 70D	1
53	45361 AL	45361 AL	45361 AL	45361 AL	Crankcase (M10)	1
56	43240 POP	43240 POP	43240 POP	43240 POP	Pan, Oil	1
64	43237 CM	43237 CM	43237 CM	43237 CM	Pin, Crosshead	3
65	48913 SHS	48913 SHS	48913 SHS	48913 SHS	Rod, Plunger, Short	3
69	43227 STZP	43227 STZP	43227 STZP	43227 STZP	Washer, Oil Seal	3
70	43228 NBR	43228 NBR	43228 NBR	43228 NBR	Seal, Oil, Crankcase	3
75	43328 S	43328 S	43328 S	43328 S	Slinger, Barrier	3
88	45697 S	45697 S	45697 S	45697 S	Washer, Keyhole (M18)	3
90	43311 CC	43311 CC	—	—	Plunger (M16x77)	3
	—	—	43232 CC	43232 CC	Plunger (M18x77)	3
95	89649 STZP	89649 STZP	89649 STZP	89649 STZP	Stud, Plunger Retainer (M6x70)	3
96	43235 PTFE	43235 PTFE	43235 PTFE	43235 PTFE	Back-up-Ring, Plunger Retainer	3
97	17399 NBR	17399 NBR	17399 NBR	17399 NBR	O-Ring, Plunger Retainer - 80D	3
	14160 FPM	14160 FPM	14160 FPM	14160 FPM	O-Ring, Plunger Retainer - 80D	3
98	45891 CU	45891 CU	45891 CU	45891 CU	Gasket, Plunger Retainer	3
99	46504 S	46504 S	46504 S	46504 S	Retainer, Plunger (M6)	3
100	45687 PVDF	45687 PVDF	45687 PVDF	45687 PVDF	Retainer, Seal, Front	3
	45686 PVDF	45686 PVDF	45686 PVDF	45686 PVDF	Retainer, Seal, Rear	3
101	43313 —	43313 —	43239 —	43239 —	Wick, Long Tab	3
106	43316 NBR	43316 NBR	43243 NBR	43243 NBR	Seal, LPS w/S-Spg	3
	106660 FPM	106660 FPM	—	—	Seal, LPS w/S-Spg	3
	—	—	44926 FPM	44926 FPM	Seal, LPS w/SS-Spg	3
120	45684 BB	45684 BB	45683 BB	45683 BB	Case, Seal	3
121	20285 NBR	20285 NBR	20285 NBR	20285 NBR	O-Ring, Seal Case - 70D	3
	11693 FPM	11693 FPM	11693 FPM	11693 FPM	O-Ring, Seal Case	3
125	—	—	43245 SNG	43245 SNG	Seal, HPS w/S	3
	—	—	44925 FPM	44925 FPM	Seal, HPS w/SS	3
126	43320 BB	43320 BB	—	—	Adapter, Female	3
127	43319 PTFE	43319 PTFE	—	—	V-Packing	6
	46287 HT	46287 HT	—	—	V-Packing	6
128	43318 BB	43318 BB	—	—	Adapter, Male	3
139	43448 BB	43448 BB	43448 BB	43448 BB	Plug, Inlet (1/2" NPT)	1
162	43248 PTFE	43248 PTFE	43248 PTFE	43248 PTFE	Back-up-Ring, Valve Seat	6
163	43249 NBR	43249 NBR	43249 NBR	43249 NBR	O-Ring, Valve Seat - 80D	6
	44383 FPM	44383 FPM	44383 FPM	44383 FPM	O-Ring, Valve Seat - 70D	6
164	43722 S	43722 S	43722 S	43722 S	Seat - Q.V.	6
	43825 S	—	43825 S	43825 S	Seat - F.V.	6
166	43721 S	43721 S	43721 S	43721 S	Valve - Q.V.	6
	43824 S	—	43824 S	43824 S	Valve - F.V.	6
167	43751 S	43751 S	43751 S	43751 S	Spring - Q.V.	6
	43823 S	—	43823 S	43823 S	Spring - F.V.	6
168	44564 PVDF	44564 PVDF	44564 PVDF	44564 PVDF	Retainer, Spring	6
172	17617 NBR	17617 NBR	17617 NBR	17617 NBR	O-Ring, Valve Plug - 90D	6
	11691 FPM	11691 FPM	11691 FPM	11691 FPM	O-Ring, Valve Plug - 90D	6
174	43850 BB	43850 BB	43850 BB	43850 BB	Plug, Valve	6
185	45549 FBB	45549 FBB	45419 FBB	45419 FBB	Head, Manifold	1
187	46868 S	46868 S	46868 S	46868 S	Stud, Manifold (M10x35)	4
194	45550 STZP	45550 STZP	45550 STZP	45550 STZP	Nut, Flanged (M10)	4
255	30243 STZP	30243 STZP	30243 STZP	30243 STZP	Kit, Direct Mount	1
260	30611 STZP	30611 STZP	30611 STZP	30611 STZP	Assy, Angle Rail, B, U.S.	
	—	30645 STZP	30645 STZP	—	(Incls: 28499 [2.09"], 30900, 30910, 30920)	1
	—	—	—	—	Assy, Angle Rail, A, U.S.	
	—	—	—	—	(Incls: 30635 [2.95"], 31129, 990777, 30910, 30920)	1
265	30660 —	30660 —	30660 —	30660 —	Kit, Mounting (Incls: 30645, 30206, 33000, 30067, 43256)	1
269	30206 F	30206 F	30206 F	30206 F	Pulley (10") [See Drive Packages Tech Bulletin 003]	1
274	33000 STL	33000 STL	33000 STL	33000 STL	Hub, "H", M24 (Keyway M8)	1
					[See Drive Packages Tech Bulletin 003]	

EXPLODED VIEW

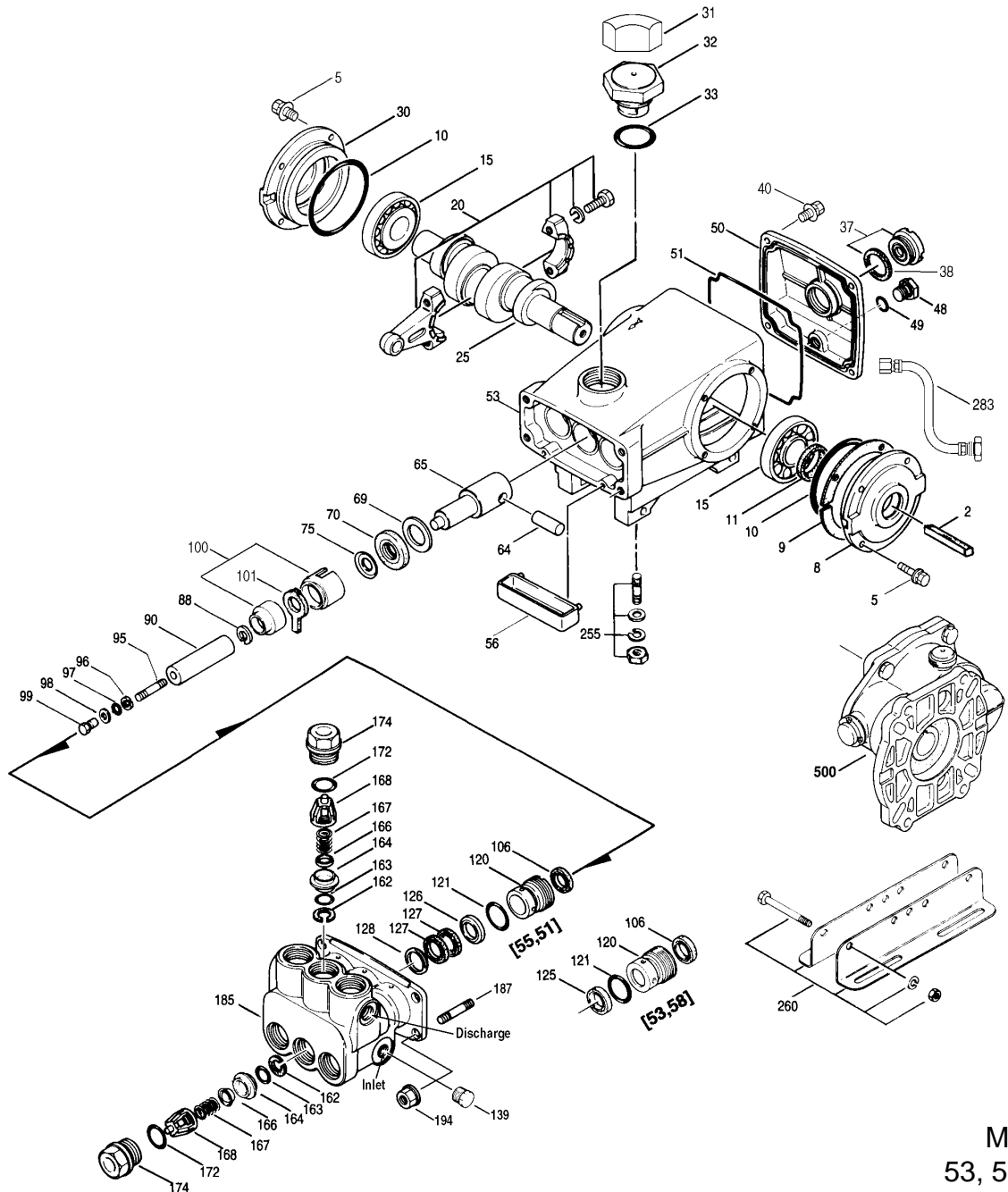

Models
53, 55, 51, 58
June 2006

	51 MATL	55 MATL	53 MATL	58 MATL				
283	34334	—	34334	—	34334	—	Kit, Oil Drain	1
299	816820 BB	816820 BB	814521 BB	814521 BB			Head, Complete	1
300	30610 NBR	30610 NBR	30488 NBR	30488 NBR			Kit, Seal (Incls: 97,101,106,121,125 or 27)	1
310	30820 NBR	30820 NBR	30820 NBR	30820 NBR	30820 NBR	30820 NBR	Kit, Valve - Q.V. (Incls: 162-164,166,167,168,172)	2
	31820 NBR	31820 NBR	31820 NBR	31820 NBR	31820 NBR	31820 NBR	Kit, Valve - F.V. (Incls: 162-164,166,167,168,172)	2
350	30696 STZP	30696 STZP	30696 STZP	30696 STZP	30696 STZP	30696 STZP	Plier, Reverse	1
351	43257 STZP	43257 STZP	43257 STZP	43257 STZP	43257 STZP	43257 STZP	Tool, Seal Case Removal	1
	33005 STZP	33005 STZP	33005 STZP	33005 STZP	33005 STZP	33005 STZP	Tool, Seal Case Socket (1/2" Drive)	1
352	44050 STZP	44050 STZP	44050 STZP	44050 STZP	44050 STZP	44050 STZP	Tool, Oil Gauge Removal	1
500	8051	—	—	—	8051	—	Gearbox (See Individual Data Sheet)	1
	8058	—	—	—	8058	—	Gearbox (See Individual Data Sheet)	1
—	6575	—	—	—	6575	—	Plunger Pump Service DVD	1
—	6107	—	—	—	6107	—	Oil, Bottle (21 oz.) ISO 68 Multi-Viscosity Hydraulic (Fill to specified crankcase capacity prior to start-up)	1

Bold print part numbers are unique to a particular pump model. *Italics are optional items.* [] Date of latest production change.

See Tech Bulletins 003, 024, 035, 036, 043, 074, 077 and 083 for additional information. See 8051-8078 Gearbox Specification Sheet for direct drive Gas Engine option.

MATERIAL CODES (Not Part of Part Number): AL=Aluminum ABS=ABS Plastic BB=Brass CC=Ceramic CM=Chrome-Moly CU=Copper F=Cast Iron

FBB=Forged Brass FBR=Fiber FCM=Forged Chrome-moly FPM=Fluorocarbon HT=Hi-Temp (EPDM Alternative) NBR=Medium Nitrile (Buna-N)

POP=Polypropylene PTFE=Pure Polytetrafluoroethylene PVDF=Polyvinylidene Fluoride RTP=Reinforced Composite S=304SS

SNG=Special Blend (Buna) SHS=304SS/High Strength STCP=Steel/Chrome Plated STL=Steel STZP=Steel/Zinc Plated TNM=Special High Strength

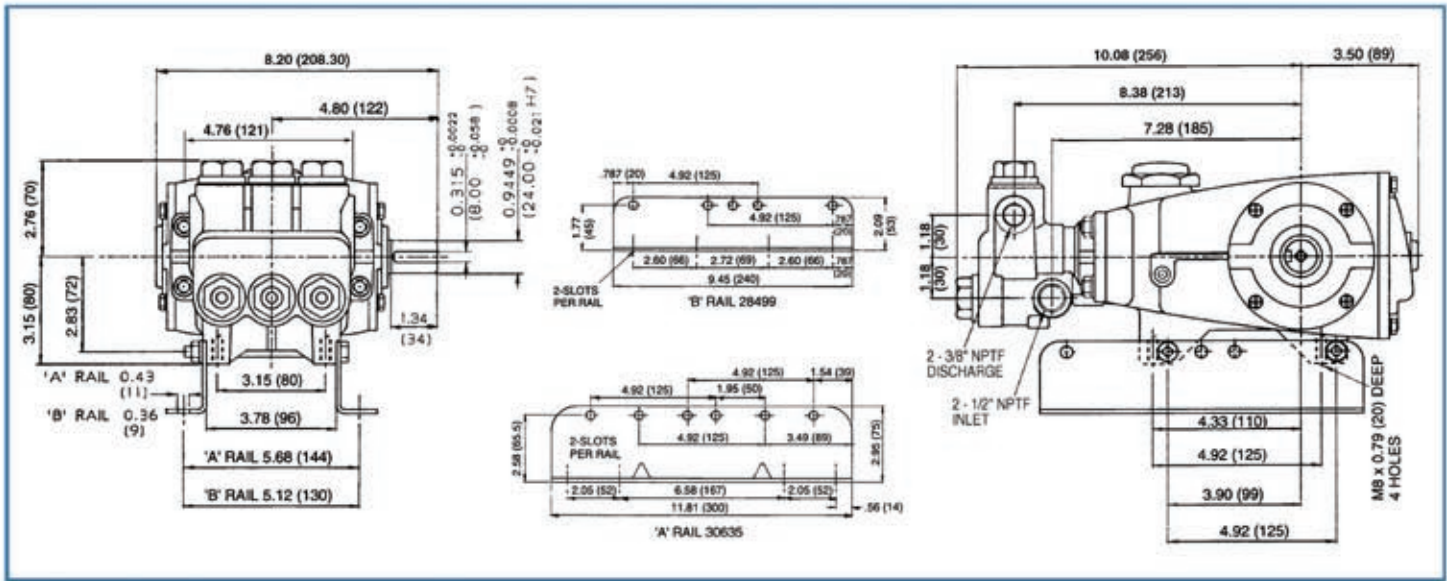

Models 53, 55, 51, 58

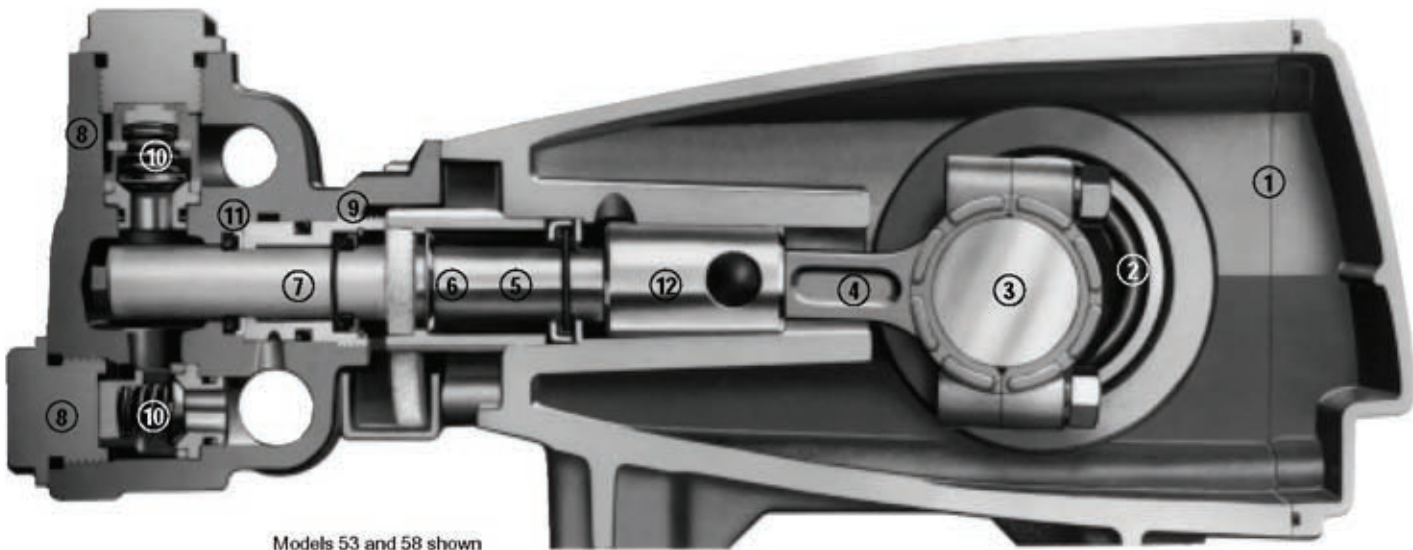

Models 53 and 58 shown

- 1 Die cast aluminum **crankcase** means high strength, lightweight, and excellent tolerance control.
- 2 Oversized crankshaft **bearings** provide extended bearing life and pump performance.
- 3 **Chrome-moly crankshaft** provides unmatched strength and surface hardness for long life.
- 4 Matched oversized high strength **connecting rods** for superior strength and bearing quality.
- 5 Special **plunger rods** with high strength crossheads for longevity and corrosion resistance.
- 6 The stainless steel **slinger** provides back-up protection for the crankcase seal, keeping pumped liquids out of the crankcase.
- 7 Special concentric, high-density, polished, solid ceramic **plungers** provide a true wear surface and extended seal life.
- 8 **Manifolds** are a high tensile strength forged brass for long term, continuous duty.
- 9 100% **wet seal** design adds to service life by allowing pumped liquids to cool and lubricate on both sides.
- 10 Stainless steel **valves, seats and springs** provide corrosion-resistance, ultimate seating and extended life.
- 11 Specially formulated, CAT PUMP exclusive, **Hi-Pressure Seals or V-Packings** offer unmatched performance and seal life.
- 12 **Crossheads** are 360° supported for uncompromising alignment.

Products described herein are covered by one or more of the following U.S. patents 3558244, 3652188, 3809508, 3920356, 3930756 and 5035580

Water Cannon, Inc.
4044 West Lake Mary Blvd
Units 140-424
Lake Mary, FL 32746
1-800-454-9274



www.watercannon.com
www.gxparts.com
www.hydromidwest.com
www.hot-superskid.com
sales@watercannon.com